



Rewarding Learning

General Certificate of Secondary Education  
2024

Centre Number

--	--	--	--	--

Candidate Number

--	--	--	--

# Physics

Unit 3: Practical Skills

Booklet A

Higher Tier



GPY33

[GPY33]

### TIME

2 hours.

### INSTRUCTIONS TO CANDIDATES

Write your Centre Number and Candidate Number in the spaces provided at the top of this page.

Write your answers in the spaces provided in this question paper.

Answer **all** questions.

### INFORMATION FOR CANDIDATES

The total mark for this paper is **30** marks.

Experiment 1 is a practical exercise worth 15 marks.

Experiment 2 is a practical exercise worth 15 marks.

Figures in brackets printed down the right-hand side of pages indicate the marks awarded to each question or part question.

Follow all health and safety instructions.

**You may not have access to notes, textbooks and other material to assist you.**

You may use a ruler and calculator if required.

The apparatus and materials required to complete the task(s) are provided.

### FOR TEACHER USE ONLY

In experiment 2 it is assumed that the candidate was given help to complete the circuit.

If this is **not** the case, please tick the box below.

No help was given

Examiner's use only	Marks
Experiment 1	
Experiment 2	
<b>Total Marks</b>	

**BLANK PAGE**

## Experiment 1 Moments

### Introduction

A force can cause an object to turn about a pivot. The force is said to have a moment.

### Aims.

1. To carry out an experiment to verify the Principle of Moments.
2. To use the Principle of Moments to determine the weight of an object.

### Apparatus

The apparatus consists of a metre rule pivoted at its mid-point as shown below.

Weight carriers are attached to the metre rule using a loop of thread which allows the weights to be moved along the metre rule.

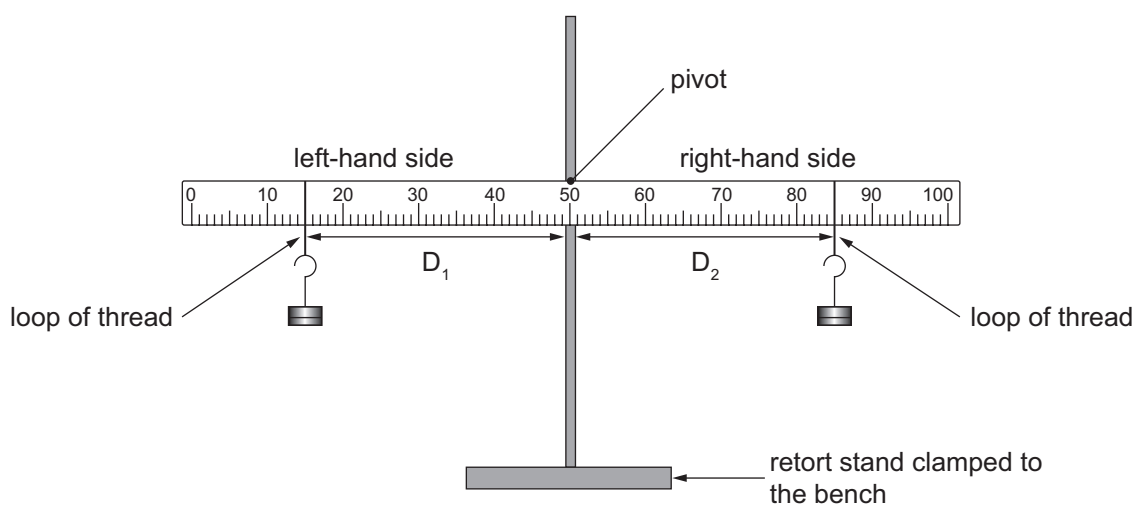

Source: Chief Examiner

(a) Procedure

During parts (a)(i) to (a)(iv) you can carry out the practical activity individually or in a group of two or three.

The metre rule has already been adjusted so that when no weights are attached it is horizontal (balanced).

- (i) Hold the metre rule so that it does not move.  
Place a **1.0 N** weight carrier on the **left-hand side** of the metre rule.  
Move the weight carrier so that it is at a distance of **20.0 cm** from the pivot.  
Record this weight  $W_1$  and distance  $D_1$  from the pivot in **Table 1**.  
Record the weight and distance to **one decimal place**.

Carefully place the other **1.0 N** weight carrier on the **right-hand side** of the metre rule.  
Add a **1.0 N** weight to this weight carrier, this provides a **2.0 N** force.  
Adjust the position of this **2.0 N** force until the metre rule is again horizontal (balanced).  
Record this weight  $W_2$  and its distance  $D_2$  from the pivot in **Table 1**.  
Record the weight and distance to **one decimal place**. [2]

- (ii) Hold the metre rule so that it does not move.  
Add a **0.5 N** weight to the weight carrier on the **left-hand side**, this provides a **1.5 N force**.  
Move this **1.5 N** force so it is at a distance of **30.0 cm** from the pivot.  
Record this weight  $W_1$  and distance  $D_1$  from the pivot in **Table 1**.  
Record the weight and distance to **one decimal place**.

Add a **1.0 N** weight to the weight carrier on the **right-hand side**, this provides a force of **3.0 N**.  
Adjust the position of this **3.0 N** force so that the metre rule is again horizontal (balanced).  
Record this weight  $W_2$  and its distance  $D_2$  from the pivot in **Table 1**.  
Record the weight and distance to **one decimal place**. [2]

- (iii) Hold the metre rule so that it does not move.  
Remove the **0.5 N** weight from the weight carrier on the **left-hand side**.  
Add **two 1.0 N** weights to this weight carrier, this provides a force of **3.0 N**.  
Move this **3.0 N** force so it is at a distance of **20.0 cm** from the pivot.  
Record this weight  $W_1$  and distance  $D_1$  from the pivot in **Table 1**.  
Record the weight and distance to **one decimal place**.

Remove a **1.0 N** weight from the weight carrier on the **right-hand side**, the force on the right-hand side is now **2.0 N**.  
Adjust the position of this **2.0 N** force so that the metre rule is again horizontal (balanced).  
Record this weight  $W_2$  and its distance  $D_2$  from the pivot in **Table 1**.  
Record the weight and distance to **one decimal place**. [2]

Examiner Only

Marks Remark

(iv) Remove the weight carrier from the **left-hand side** of the metre rule. Place the weight marked **W** on the **left-hand side** of the metre rule. Move the weight marked **W** so that it is at a distance of **30.0 cm** from the pivot. Record this distance **D<sub>1</sub>** from the pivot in **Table 1**. Record the distance to **one decimal place**.

Add a **1.0 N** weight to the weight carrier on the **right-hand side**, this provides a force of **3.0 N**. Adjust the position of this **3.0 N** force so that the metre rule is again horizontal (balanced). Record this weight **W<sub>2</sub>** and its distance **D<sub>2</sub>** from the pivot in **Table 1**. Record the weight and distance to **one decimal place**. [2]

**When you have recorded the weights and distances, remove all the weights from the metre rule.**

**Table 1**

	Left-hand side		Right-hand side	
	W <sub>1</sub> /N	D <sub>1</sub> /cm	W <sub>2</sub> /N	D <sub>2</sub> /cm
(a) (i) →				
(a) (ii) →				
(a) (iii) →				
(a) (iv) →	<b>W</b>			

**When you have taken all the measurements or when your teacher tells you that 30 minutes are over stop using the apparatus.**

**To complete the remainder of this assessment you must work alone.**

**Your teacher will direct you to a place in the room to do this.**

Examiner Only	
Marks	Remark



**(c) Interpretation of your data**

(i) Your measurements verify the Principle of Moments, explain how.

---

---

---

[2]

(ii) Using your data recorded at (a)(iv) in **Table 1**, calculate the weight of the object marked **W**.

Record the weight of **W** to **one decimal place**.

**Show clearly your calculations.**

Weight of **W** = \_\_\_\_\_ N [1]

Examiner Only	
Marks	Remark

**BLANK PAGE**

## Experiment 2 Resistance of a wire

### Introduction

The wire has electrical resistance and the current passing through it will depend on the length of wire.

### Aim

The aim of the experiment is to obtain the voltage and current measurements for different lengths of a wire at **constant temperature** and use these measurements to calculate the resistance.

You will use your results to plot a graph of the resistance of the wire and its length.

The diagram below shows the circuit that you will use in this experiment.

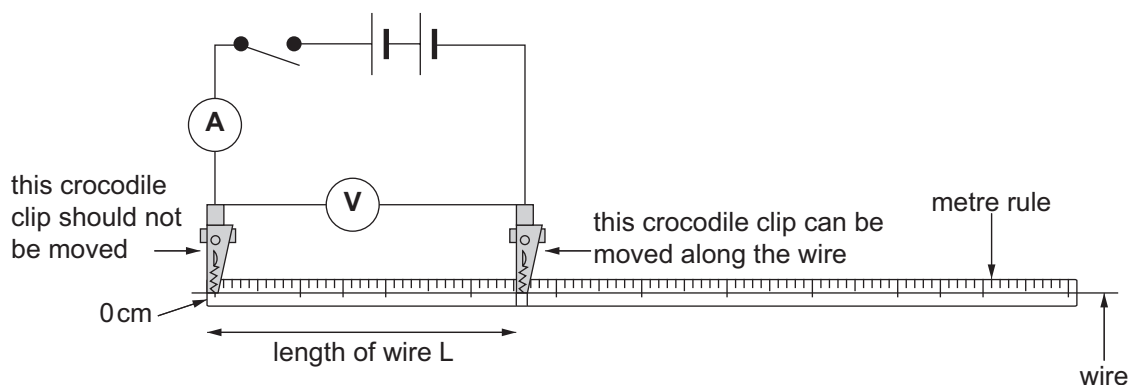

Source: Chief Examiner

During parts (a)(i) to (iii) you can carry out the practical activity individually or in a group of two or three.

Examiner Only	
Marks	Remark

**(a) Procedure**

- (i) Part of the circuit has already been built.  
Complete the circuit by adding the ammeter and voltmeter.

**You must not adjust the power supply during the experiment.  
Before proceeding you must have the circuit checked by your teacher.**

[1]

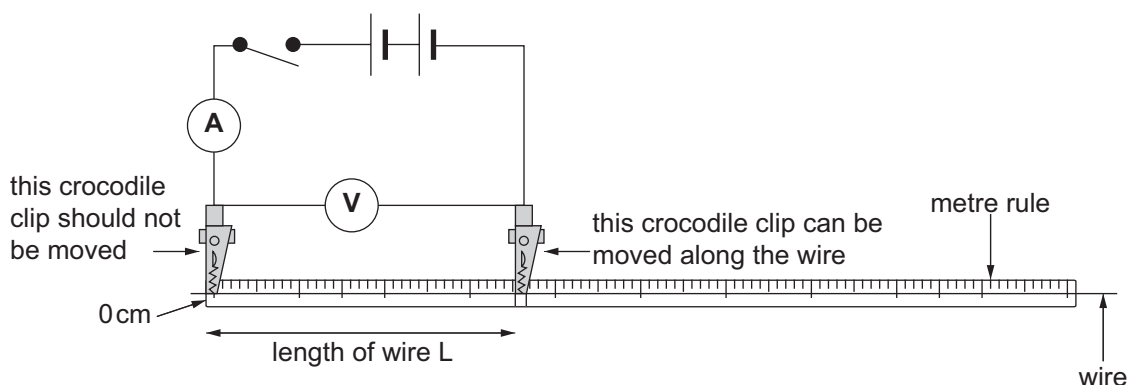

Source: Chief Examiner

- (ii) Complete **Table 3** opposite by adding the missing units to the headings of **columns 2 and 3**.

[1]

- (iii) Position the moveable crocodile clip so that a 20 cm length ( $L$ ) of wire is connected into the circuit.

Close the switch and record the voltage and current readings in the table for this length.

Record your readings to **one decimal place**.

**Open the switch.**

Next, position the moveable crocodile clip so that a 40 cm length of wire is connected into the circuit.

Close the switch and record the voltage and current to **one decimal place** in the table.

**Open the switch.**

Repeat the procedure until you have sets of voltage and current readings for 60 cm and 80 cm lengths of wire.

**Open the switch after you have recorded each voltage and current measurement.**

[3]

## Results

Table 3

Column 1	Column 2	Column 3	Column 4
Length of wire L/cm	Voltage/	Current/	
20			
40			
60			
80			

**When you have taken all of your measurements or when your teacher tells you that 30 minutes are over stop using the apparatus.**

**To complete the remainder of the assessment you must work alone.**

**Your teacher will direct you to a place in the room to do this.**



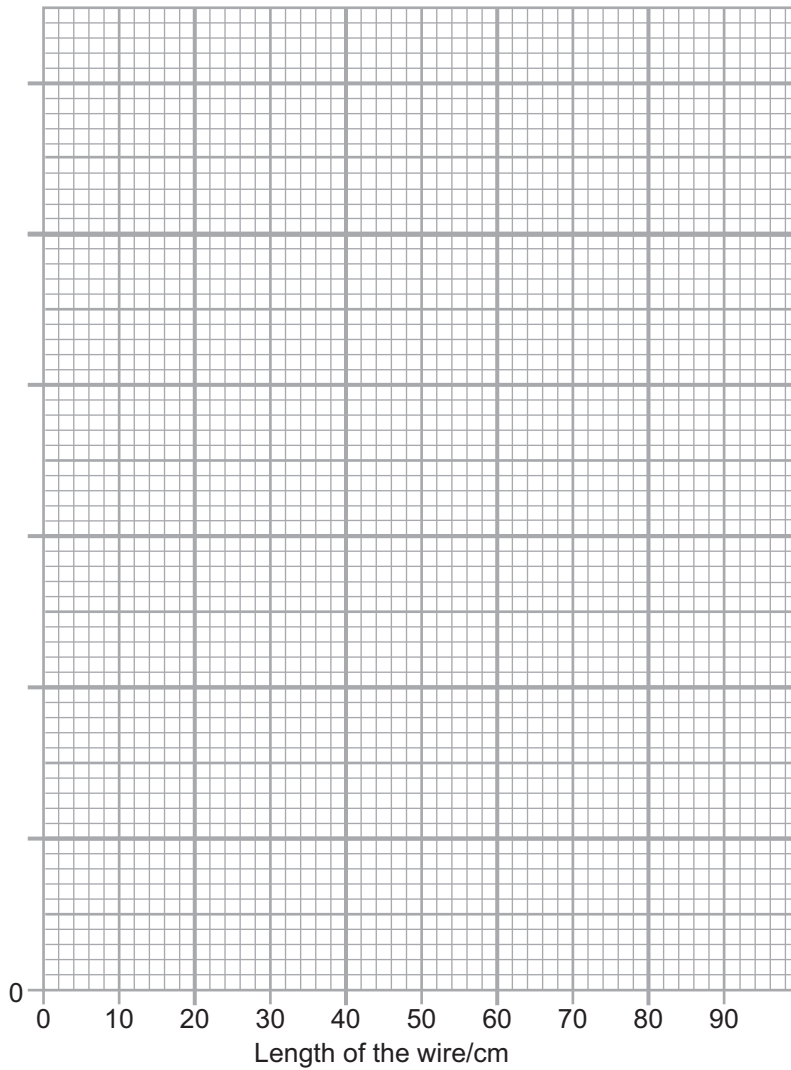

Examiner Only	
Marks	Remark

The resistance of the wire and its length are related by the equation below.

$$R = kL$$

R = the resistance of the wire in ohms ( $\Omega$ )

L = the length of the wire in cm

k = a constant

(iii) Using your line of best fit, find the value of k. State the unit of k.

**Show clearly how you get your answer.**

k = \_\_\_\_\_

Unit of k = \_\_\_\_\_ [2]

---

**THIS IS THE END OF THE QUESTION PAPER**

---



Permission to reproduce all copyright material has been applied for.  
In some cases, efforts to contact copyright holders may have been unsuccessful and CCEA  
will be happy to rectify any omissions of acknowledgement in future if notified.